

Overview

The Unipower APM426 is a combined Electronic Power Measurement Transducer and Load Monitor that measures power in kW on 3-phased asymmetric loads, also after frequency inverters, according to the formula:

$$P = \sqrt{3} \times U \times I \times \text{Cos}\varphi$$

- * Suitable for mains voltages from 3x230V to 3x575V
- * Measures after frequency inverters; PWM 10Hz - 1kHz
- * 10 Current measuring ranges up to 80A internally
- * Digital scaling of the selected range (Zoom)
- * 2 independent alarm limits
- * Separate current range for each limit
- * Active limit selectable via external input
- * Alarm inhibit inputs and external reset input
- * Optocoupled alarm outputs
- * 0(4)-20mA and 0(2)-10V analogue outputs
- * Galvanic isolation between mains net and I/O (incl. 24V)
- * Setup via PC with software 426Mon



Features

Voltage measurement

The APM426 is suitable for mains voltages from 3x230V to 3x575V. The integrated measurement system is designed for measuring after frequency inverters - i.e. between the frequency inverter and the motor. Hence the APM426 is not powered by the measuring voltage like the majority of the Unipower products, but by a 24Vdc. One of 7 mains voltage ranges is selectable via PC-software.

Current measurement

The APM426 directly measures up to 80A with internal CTs. To take advantage of the large measurement range, the unit has 10 current ranges making APM426 suitable for nominal currents below 1A and up to 80A. The current range is also set via the PC-software.

Power measurement

The power measurement is performed by a specially developed circuit which is capable of measuring the waveform of the voltage and current signals on the output of a frequency inverter. The unit contains a 4 step programmable analogue filter which may be used to improve accuracy at frequencies down to 10Hz.

Analogue output

The APM426 features voltage and current outputs configurable as 0-20mA (0-10V) or 4-20mA (2-10V). It is not possible to generate 0-10V

and 4-20mA simultaneously. 20mA (10V) is generated at nominal current, nominal voltage and $\text{cos}\varphi=1$.

Digital inputs

The unit is equipped with 6 digital inputs. In the standard version only S1 - S5 are used. All digital inputs are activated (On) when connected to the +12V output (23), or an external +12-24Vdc source.

Digital outputs

Two optocoupler outputs (Out1 and Out2) are available for signalling alarms. They are On under normal conditions (A connection exists between + and - for the output in question) and Off during alarms (The connection between + and - for the output in question is removed). The output function may be inverted but is set common for both outputs.

LED indicators

The APM426 has 4 LED indicators. The LED marked „Load“ indicates that the 24Vdc is connected. If the measured load is below 3% of the measuring range this LED flashes. The LED marked „Aux“ is used as indicator for the start timer (Ts). The LEDs marked „Limit 1“ and „Limit 2“ indicate the status of the two limits; LED On = Tr active, LED flashing = Alarm.

Technical Specifications

Mechanical

| | |
|------------|--|
| Housing: | Lexan UL94V-0 (Top) Noryl UL94V-0 (Bottom) |
| Mounting: | M36 for 35 mm DIN rail |
| IP class: | Housing IP40. Terminals IP20 |
| Terminals: | Max 16A. Max 2,5 mm ² Terminal tight. torque: 7lbs/in, 0.79Nm Use 60/75 copper (CU) wire only |
| Temp.: | -15 to +50 °C surrounding air |
| Weight: | 300 g |
| Dimens.: | D 58 x W 102 x H 86 mm |



EN61326-1, EN61010-1
(EU)



UL508, File E350194
(USA & Canada)

Electrical

| | |
|----------------------|----------------------------|
| Supply: | 24Vdc ±10%, max 150mA |
| Measurement voltage: | Max. 3x600V (PWM) |
| Current input: | Nominal 80A, Max. 130A |
| Frequency: | 10Hz - 1kHz |
| Accuracy: | Class 2% |
| Analogue output 1: | 0(4)-20 mA max 300Ω |
| Analogue output 2: | 0(2)-10V min load 10kΩ |
| Digital inputs: | 12 - 24V DC |
| Digital outputs: | Optocoupler, max. 30V/30mA |
| Serial port: | RS232C, 9600 Baud |

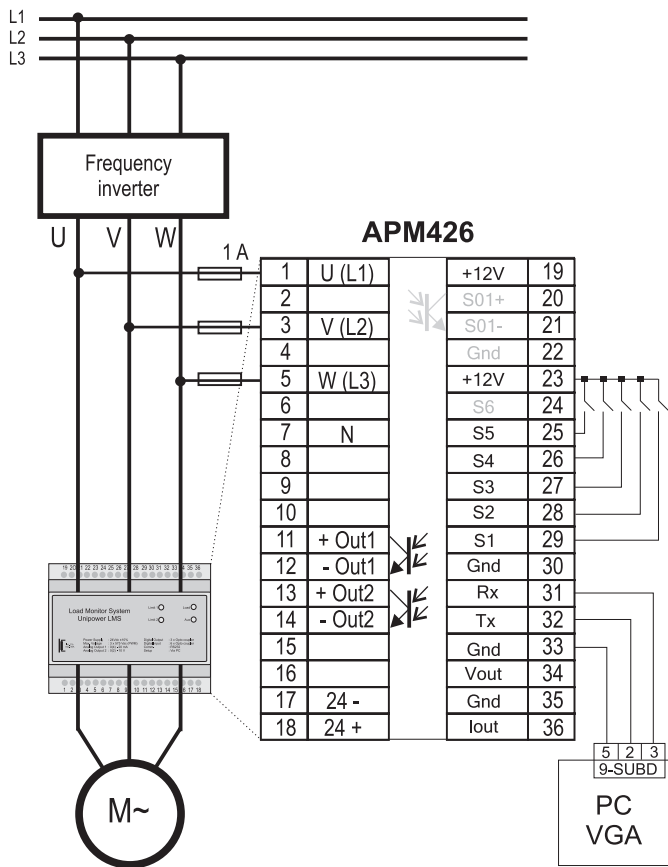

Example with frequency inverter

- Output** : 1 (Common output) or 2 (Separate outputs)
- Output polarity** : Noninverted or inverted
- Auto Shut Down** : On or Off

Please refer to „Technical description“ on our website: www.unipower.dk for a thorough description of the parameters and their function.

Load monitor

APM426 contains two independent load monitors of which only one is active at a time. The limits may use a common output (Always output 1) or separate outputs (Both output 1 and 2). The parameter „Output“ (See above) must be 1 for common output and 2 for separate outputs. The settings for each limit are as follows:

- Limit** : Min or Max
- Setpoint** : 5 - 99 % (Of the measuring range)
- Ts** : 0,0 - 25,0 s
- Tr** : 0,0 - 25,0 s
- Current range** : 1, 5, 10, 20, 30, 40, 50, 60, 70 or 80A

Both limits may be set independently of each other and run one at a time. Which limit is active is selected via digital input S2;
S2 Off:Limit 1 is active
S2 On:Limit 2 is active

Off means not connected - i.e. with open switch as shown in the example to the left. On means with closed switch.

When changing active limit a new start timer is activated corresponding to the Ts for the activated limit.

Reset of an alarm may be done independently of which limit is active - provided that the condition resulting in the alarm is no longer present.

Installation

The APM426 is connected to the mains and load as shown in the drawing above. The example is shown where a frequency inverter is used. If this is not the case, L1, L2 and L3 are connected directly to the mains. The three motor cables are lead through the tubes mounted in the unit. Each tube is encircled by a special CT capable of measuring currents linearly up to 130A. The CTs can withstand start-up currents up to 500A. For correct measurement the live wires must be lead through the correct tube as shown in the drawing. The direction of the current is not important but must be the same for all three phases.

Measuring Range

Setting up the measuring range in the APM426 is done choosing nominal current and voltage. Based on this the power range may be calculated according to:

$$P_{\text{Range}} = \sqrt{3} * U * I$$

All setpoints are entered in % of the measuring range and the analogue outputs are also directly proportional to it as well; 20mA (10V) corresponds to a measurement of P_{Range} kW.

Setup

All setup in the APM426 is done using a PC with the software 426Mon. (See users guide about how to install and use 426Mon). The basic setup of APM426 consists of the parameters:

- Voltage range** : 230V - 575V (7 ranges)
- Iout** : 0-20mA or 4-20mA (0-10V or 2-10V)
- Zoom - P1Max** : 40 - 100% (Of the range)

Digital Input

| | |
|----|----------------------------|
| S1 | External reset |
| S2 | Limitselect |
| S3 | Alarm blocking |
| S4 | Analogue filter (figure 2) |
| S5 | Analogue filter (figure 2) |

Filter

| Filter | S4(26) | S5(25) |
|--------|--------|--------|
| 200 ms | On | On |
| 80 ms | Off | On |
| 40 ms | On | Off |
| 20 ms | Off | Off |

Figure 2 Analogue filter

Figure 1 Digital input

Digital output

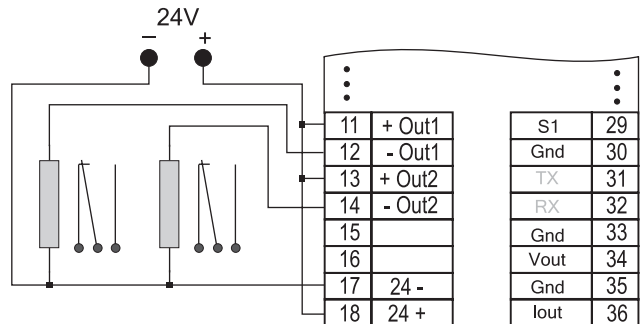

Figure 1 Ex. on the digital outputs connected to external relays