

Display & Programming.

Mode	Function	Parameter	▼	▲	Display	Default
Meas'mt	Display measurement		Min. peak	Max. peak	Meas'mt [%]	
Limits	Limit 1 prog./display	Off,5-100%	Decrease	Increase	Limit 1	80
Limits	Limit 2 prog./display	Off,5-100%	Decrease	Increase	Limit 2	Off
Ts [S]	Start timer	0.0-25.0 Sec.	Decrease	Increase	Ts [Sec]	2.0 Sec.
Tr [S]	Alarm reaction timer 1	0.0-25.0 Sec.	Decrease	Increase	Tr [Sec]	0.1 Sec.
Tr [S]	Alarm reaction timer 2	0.0-25.0 Sec.	Decrease	Increase	Tr [Sec]	0.1 Sec.
Hyst's	Hysteresis 1	5-50%	Decrease	Increase	Hyst's [%]	10
Hyst's	Hysteresis 2	5-50%	Decrease	Increase	Hyst's [%]	10
Units						
Full scale	Max. input	20-100%	Decrease	Increase	'Fullscale'	100
Offset	Offset adjustment±	±10%(F.S.)	Decrease	Increase	Meas'mt [%]	---
Input	Input select	Vdiff, 10V, 20mA	Vdiff-10V-20mA	20mA-10V-Vdiff	"Inp"	Vdiff

HPL220 is programmed by the use of only three keys located on the front panel, see the paragraph about programming on page 2. All parameters as well as their range are listed in the table above. The parameters are stored in EEPROM. When no key has been activated for about 5 seconds, the display returns to the „Meas'mt“ position, except for the offset adjustment, where the display continuously shows the actual measurement for adjustment.

Note: The unit is equipped with accelerator on the keys, so the function of the keys is repeated if the keys are held down continuously.

Note! Only one of the inputs (vDiff, 0-10V, 0-20mA) may be used.

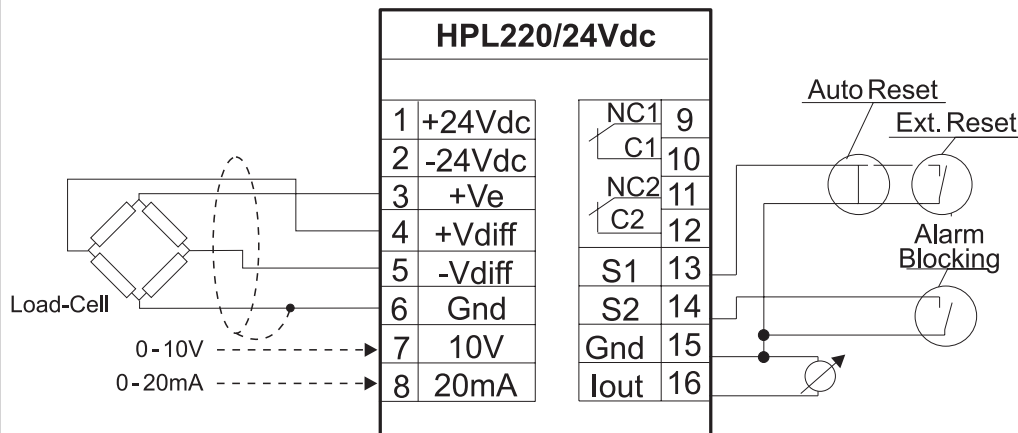

Example: HPL220 connected to a load-cell

Unipower

HPL220/24Vdc

Version 4.0

Technical information

English edition

Technical Specifications

Mechanical

Housing

Makrolon 8020 (30% GV), UL94V-1 (housing). Makrolon 2800, UL94V-2 (connector + front).

Mounting

Snap-on construction for 35mm DIN-rail or wall mounting.

Protection class

IP40 (housing).
IP20 (connector).

Temperature range: -15 - +50 °C.

Weight: Ca. 350g.

Dimensions: D 110 x W 56 x H 75 mm.

Electrical

Supply

24 Vdc ±10%

Measuring range

Vdiff: 20 - 100mV full scale, 100kΩ

10V: 0-10V, 850kΩ

20mA: 0-20mA, 5Ω

Consumption: 2 VA

Transducer Supply

10V stabilized max. load 330Ω.

Relay: 48Vac/dc, 5Amp.

Analogue output.

4-20mA, 0-400Ω.

The output is electrically isolated from the measurement system, but not from the supply.

CE-mark to:

EN61326-1, EN61010-1

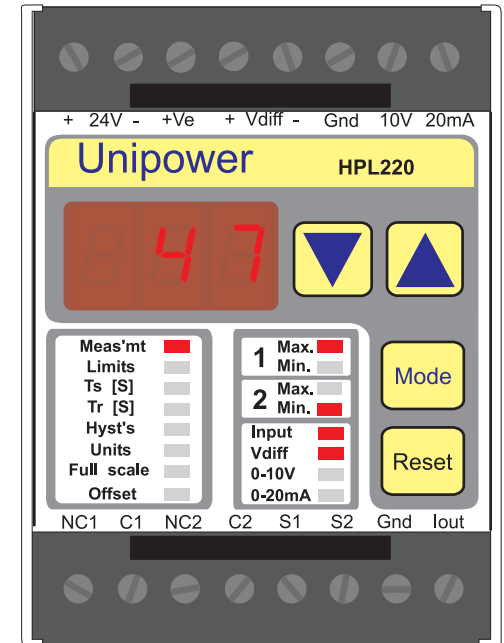

The CONCEPT

The Unipower HPL220 is a member of a family of **"Intelligent Control Units"** which is based upon the latest advance in the Microcontroller Technology. The HPL220 operates as both a measurement transducer and a signal conditioner for many different types of transducers. The device includes 2 trip points and associated relay outputs, timers and hysteresis functions which makes it an extremely flexible control unit. The HPL220 accepts 3 different types of transducer signals: 0-100 mV differential, 0-10V and 0-20mA. Each signal range is scalable with respect to span and offset. The lowest measurement range is 20mV F.S. The unit has a stabilized 10V supply for the transducer. The display shows the measurement in % of the range.

WENtechnology

Generally

The HPL220 is often used together with a load-cell to protect motor driven machinery against overload etc. Other members of the HPL-family realize the same function from the measurement of the power consumption of the motor. The HPL220 is used in special cases where the power-consumption of the motor varies little as a function of the change of load. This is for example true when the motor uses a gear with a very large exchange ratio. The drawing below shows a possible load curve of a machine taken immediately after starting.

Programming:

HPL220 is programmed by the use of only three keys located on the front panel. The „Mode“-key is used to select one of the programmable parameters: When a parameter is selected its value may be altered using the arrow keys.

Measuring range:

Setting up the measuring range for the HPL220 consists of three settings: Selecting input (transducer output), Full scale and offset adjustment.

Input:

Using the arrow keys to select the 'input' to match the output of the transducer. The transducer is interfaced to the HPL220 terminals, which corresponds to the input selected.

Full scale:

The arrow keys are used to change the range continuously between 20% and 100%.

Offset adjustment:

The offset must be adjusted with the input signal = 0. The display shows the actual measurement. Using the arrow keys adjust the offset, until the display shows 0. At full scale above 50mV the arrow keys typically needs to be activated more than once to provide a change in the displayed value.

Note! Adjustment only applies to Vdiff-input.

Absolute measurement:

The HPL220 measures bipolar input signal, but is able to show only up to 10% of full scale below zero. If the Dip. Sw. 2 is set to pos. '0' negative signals are inverted.

Choosing limits:

Determining the limits can be done using the peak detectors in the HPL220.

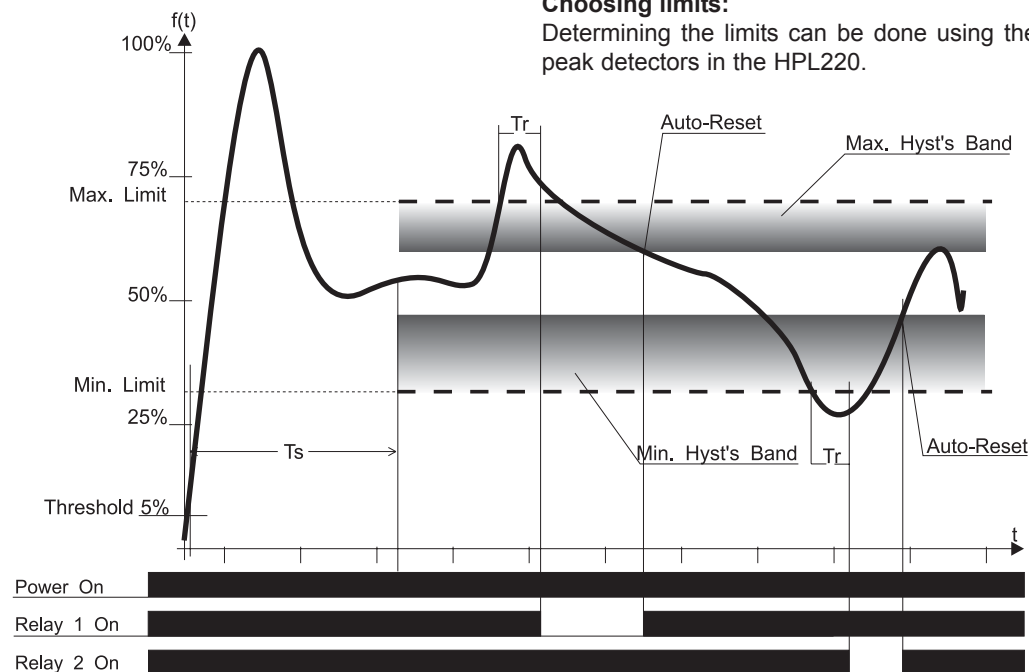

Peak detectors:

Leave the system running at normal load and read the peak values by activating the arrow keys in „Meas'mt“-mode. The Max.peak is shown by arrow-up and the Min.Peak by arrow down. Place the Min limit appropriately below the Min peak value. Peak values are set to actual measurement by expiration of Ts. They may be reset separately by pressing the relevant arrow key and at the same time activate the Reset key.

Ts: Start timer

The start timer (Ts) is used to avoid alarms at system start. The Ts delay function is activated after the input signal reaches 5%. When Ts expires the limits, hysteresis and Tr become active. If the input signal drops below 5%, the supervision is switched off again.

Tr: Reaction timer

The figure shows how the reaction timer (Tr) is activated after the limit is exceeded. Tr is used to avoid alarms, unless the limit has been exceeded for a certain time. If Tr is set to 0, Tr ~ 50ms.

Resetting alarms:

Alarms may be reset by the reset key on the front panel or by Input S1.

Input S1: Auto or external reset

External reset: S1 is connected to Gnd using a switch or optocoupler output. See fig. below.

Auto reset: If S1 is connected to Gnd, Auto reset mode is enabled, which leads to reset of alarms by hysteresis.

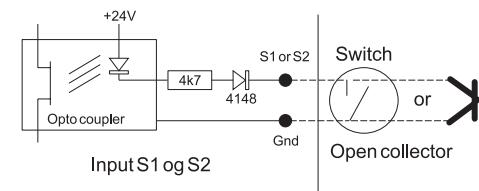

Hysteresis:

The figure to the left shows how a possible hysteresis band is placed relative to the limits; Always above a Min limit and below a Max limit. Hysteresis is activated when an alarm is generated and the external reset is active (Input S1, Auto reset mode).

Input S2: Blocking of alarms

Like Ts blocks for alarms during start up, alarms can be ignored by connecting S2 to Gnd.

Ex. 1: If a brief overload is expected, a PLC output or the like may be used to block for a short period of time.

Ex. 2: If the Min. limit is used, a spare break switch from the Motor Switch must be connected between the S2 input and Gnd, otherwise an alarm is generated each time the motor is switched off on purpose.

DIP switch:

The DIP switch is found immediately below the front plate (see the figure below).

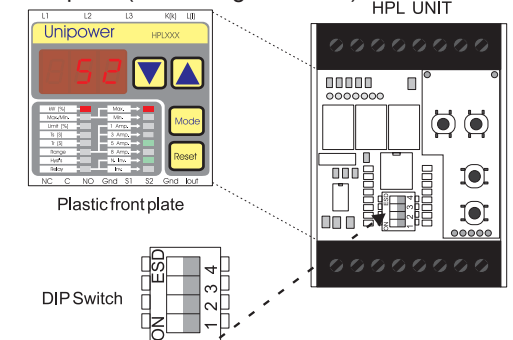

1. Turn off the unit.
2. Remove the plastic front plate (use a small screwdriver).
3. Make the changes and reassemble the unit.

DIP Switch Usage		
SW 1	Programming protection off	Off
SW 1	Programming protection on	On
SW 2	Bipolar mode	Off
SW 2	Unipolar (absolute) mode	On
SW 3	Limit 1 = Max. Limit	Off
SW 3	Limit 1 = Min. Limit	On
SW 4	Limit 2 = Max. Limit	Off
SW 4	Limit 2 = Min. Limit	On

Note! DIP switches 2,3 & 4 are only read during power up.

LED-usage:

LED Usage	
Limit 1 active	Max/Min 1 LED On
Limit 2 active	Max/Min 2 LED On
Alarm 1 active	Max/Min 1 LED flashes
Alarm 2 active	Max/Min 2 LED flashes
Start delay active	Ts LED On
Alarm delay active	Tr LED On